



LCD-Shield-Python

Version **0.9**
License **GNU GPL v3**
Adobe **PDF**
LC-Display **EA DOGS104**
LCD-Controller **SSD1803A**

Download **zip**

LCD-Shield for the Maker Pi Pico Board.

1. Schematic

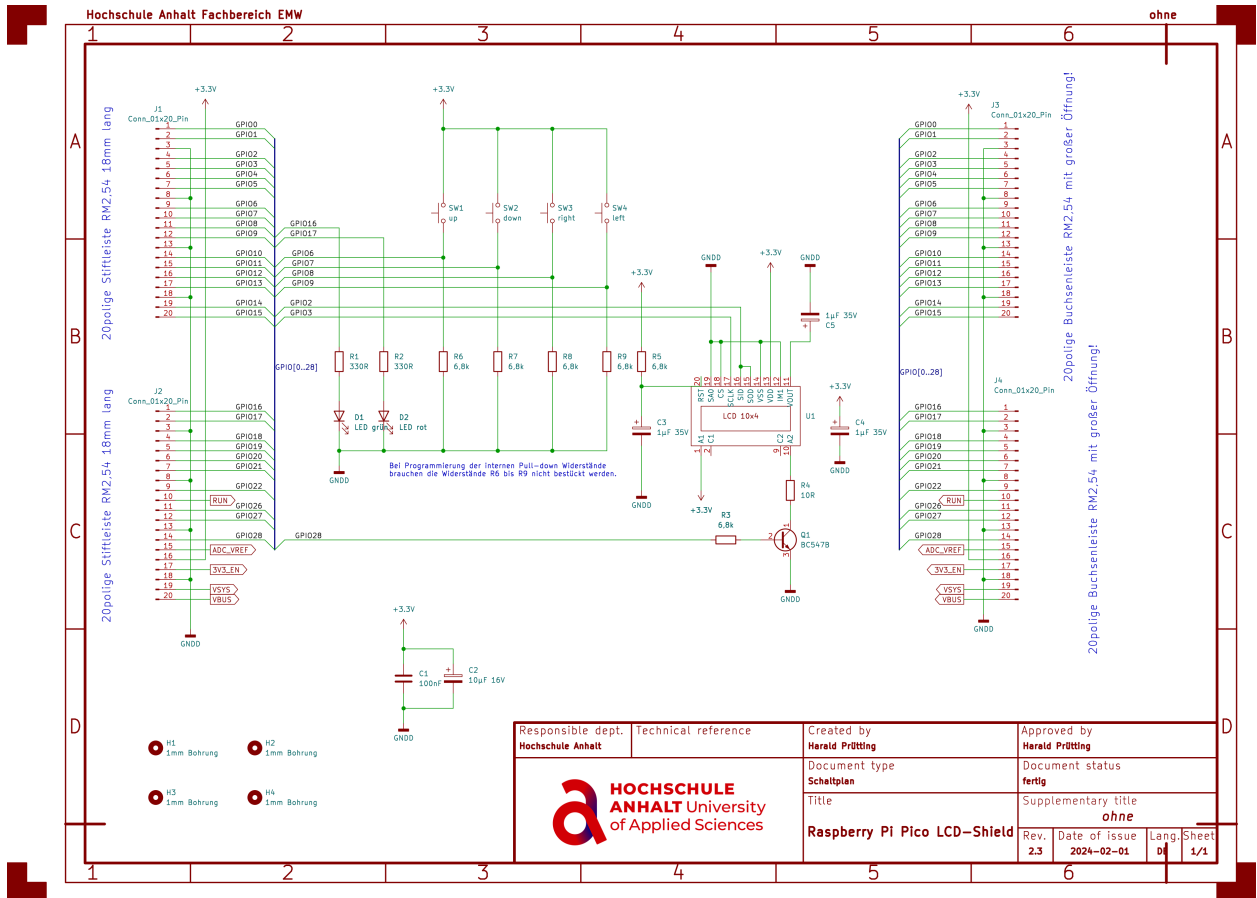

2. Pinout

Component	Pin	Comment
LCD I2C SDA	GP2	I2C Data Line
LCD I2C SCL	GP3	I2C Clock Line

Component	Pin	Comment
LCD Backlight	GP28	LCD Backlight (dimnable)
Button Up	GP6	Button active high (pull-down requiered)
Button Down	GP7	Button active high (pull-down requiered)
Button Right	GP8	Button active high (pull-down requiered)
Button Left	GP9	Button active high (pull-down requiered)
LED Green	GP16	LED active high (dimnable)
LED Red	GP17	LED active high (dimnable)

3. Bibliography

[1] Micropython Docs

Quick reference for the RP2

<https://docs.micropython.org/en/latest/rp2/quickref.html#>

Abfragedatum: 23.08.2023

[2] SOLOMON SYSTECH

Display-Controller: SSD1803A

https://www.lcd-module.de/fileadmin/eng/pdf/zubehoer/ssd1803a_2_0.pdf

Abfragedatum: 20.04.2018

[3] LCD-Module

LC-Display: EA DOGS104-A

<https://www.lcd-module.com/fileadmin/eng/pdf/doma/dogs104e.pdf>

Abfragedatum: 20.04.2018

Hochschule Anhalt | Anhalt University of Applied Sciences | Fachbereich 6 EMW

Prof. Dr.-Ing. Ingo Chmielewski

 Ingo.Chmielewski@HS-Anhalt.de

Tobias Müller, M. Eng.

 Tobias.Mueller@HS-Anhalt.de

Dipl. Ing. Harald Prütting

 Harald.Pruetting@HS-Anhalt.de

© es-lab.de, 26.03.2024